

FIRST ANGLE PROJECTION — DO NOT SCALE — IF IN DOUBT ASK — ALL MEASUREMENTS IN MM — REMOVE ALL SHARP EDGES — TOLERANCES UNLESS STATED LINEAR±0.5 TOL/ ANGULAR±0.5 DEG.

REMARKS:

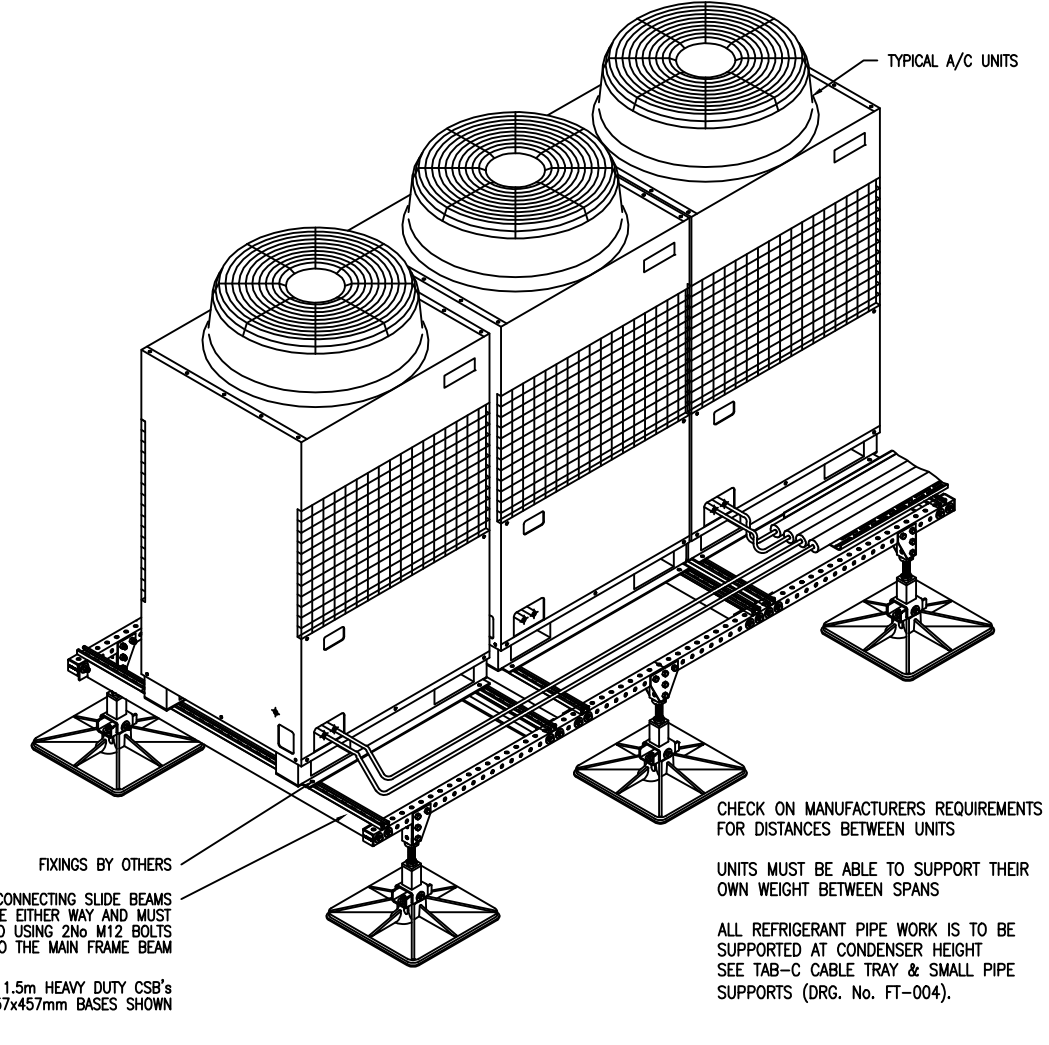
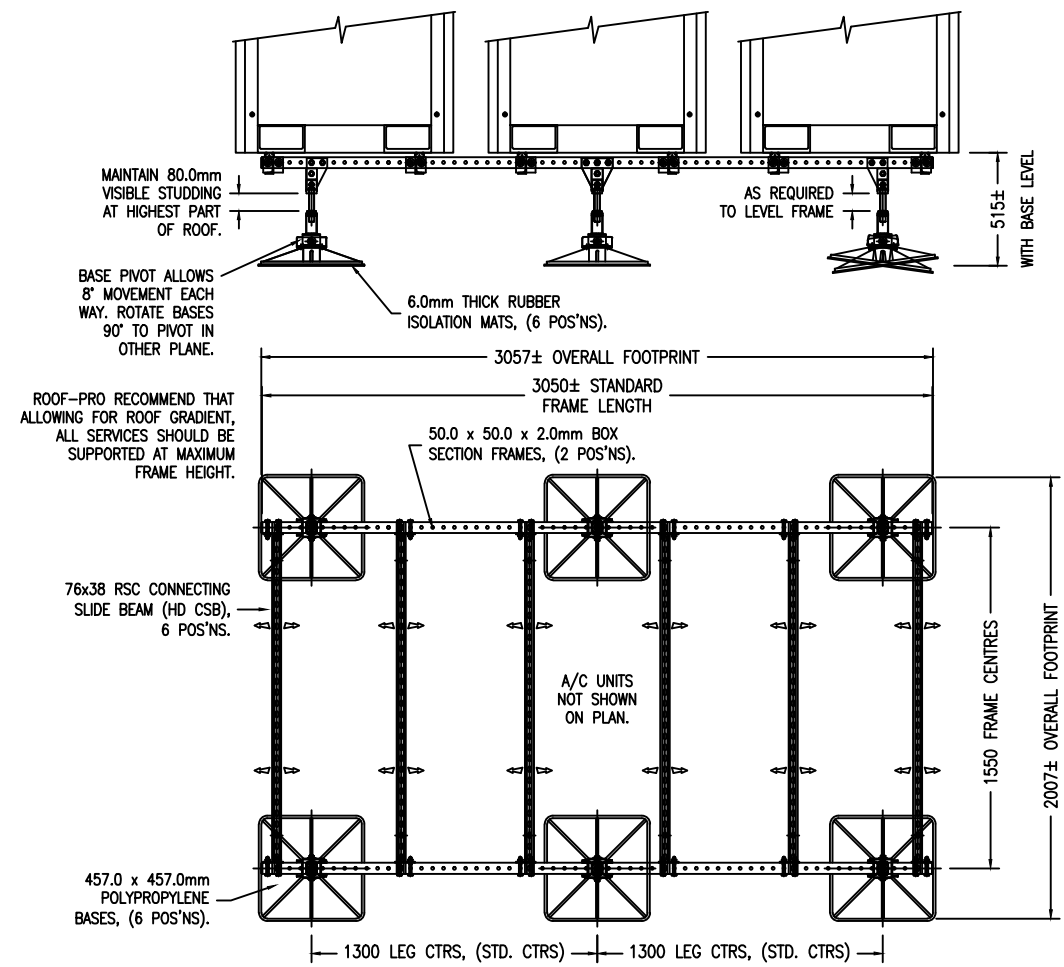
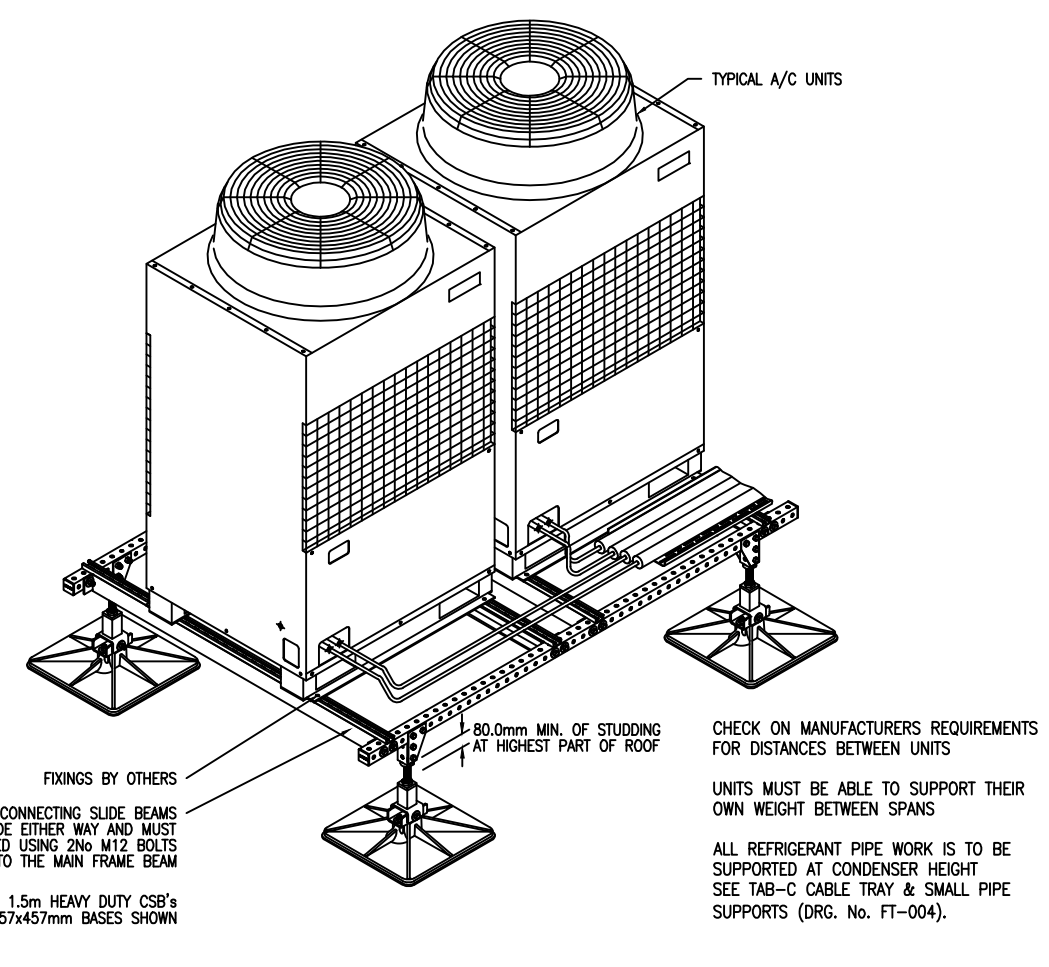
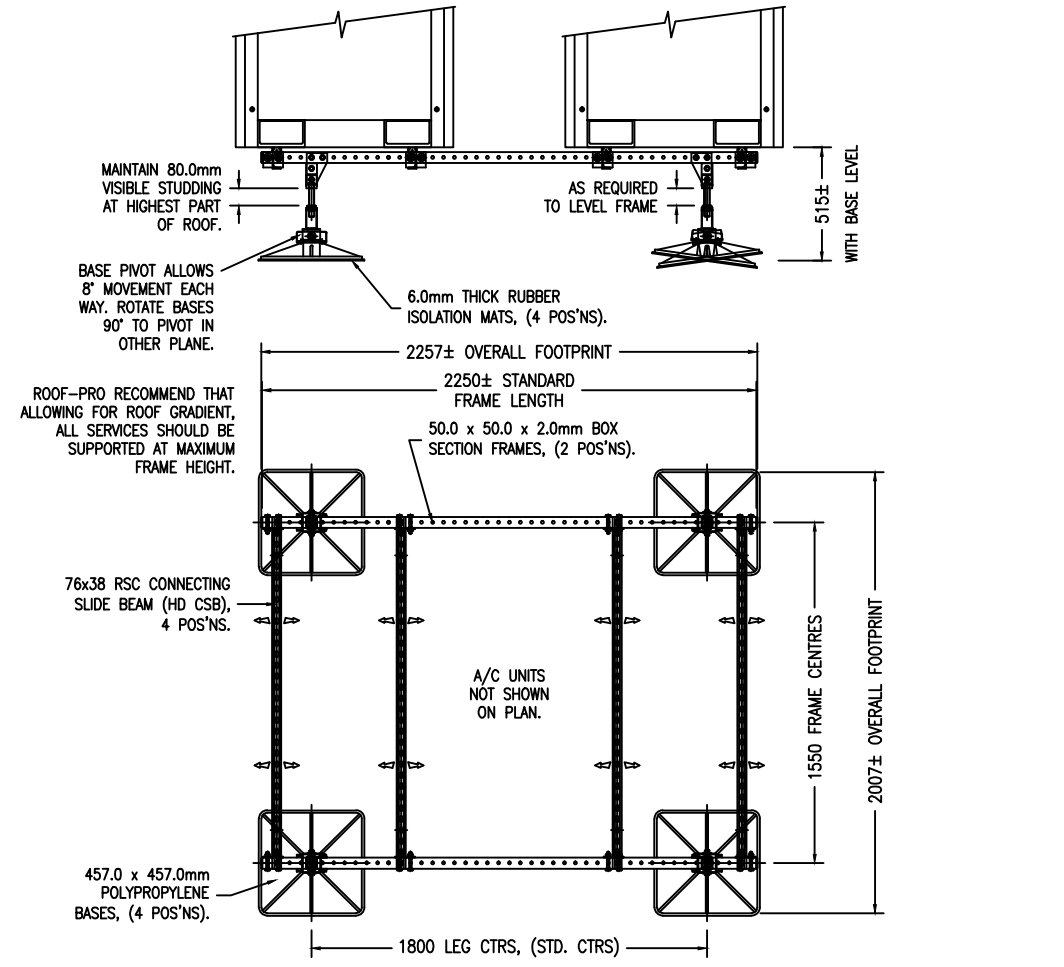

© COPYRIGHT ROOF-PRO

ISSUE 10	
ISSUE 9	
ISSUE 8	
ISSUE 7	
ISSUE 6	
ISSUE 5	
ISSUE 4	
ISSUE 3	
ISSUE 2	02.03.16
ISSUE 1	11.05.12

ROOF-PRO
ROOFTOP MANAGEMENT SYSTEMS

Polwell Lane, off Station Road
Burton Latimer NN15 5PS, UK
Tel: +44 (0)1744 648 400
Email: cad@roof-pro.co.uk
Website: www.roof-pro.co.uk

PRODUCT:
PF2 18x6TP 1.5m HD CSB's
PF3 18x4TP 1.5m HD CSB's
TYPICAL PRODUCT RANGE

MATERIAL/FINISH:

MILD STEEL
HOT DIP GALVANISED

SCALE @ A3:	N.T.S.
DRAWN BY:	CAD
DATE:	11/05/12
CHECKED BY:	CAD
DATE:	11/05/12
DRAWING No:	FT-014